

XSTAND^{BY} Xwave 32/75

UPUTSTVO ZA UPOTREBU

32"-75"
Max VESA: 600x400mm
Okretanje: +/- 60°
Nosivost: 40kg

Kesica sa priborom

A

M6x35mm
(x7)



B

M6x10mm (x4) Anti klizajuće podloške S=4mm (x4) S=4mm (x1)



C

M4x20mm
(x4)

M5x20mm
(x4)

M6x20mm
(x4)

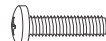

M5x40mm
(x2)

10mm sleeves
(x4)

D6 podloška
(x4)



1 Instalacija antiklizajućih podloški

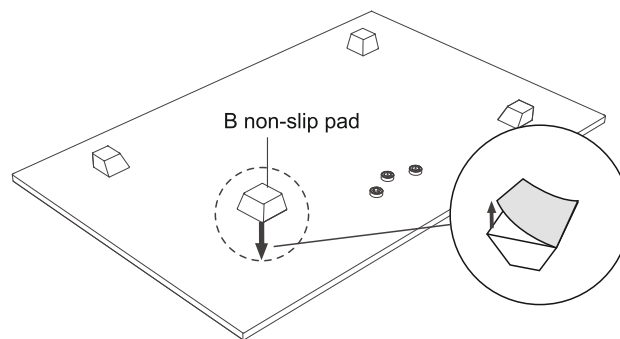

Prilepite 4 ne klizajuće podloške u ćoškovima

2 Instalacija stuba

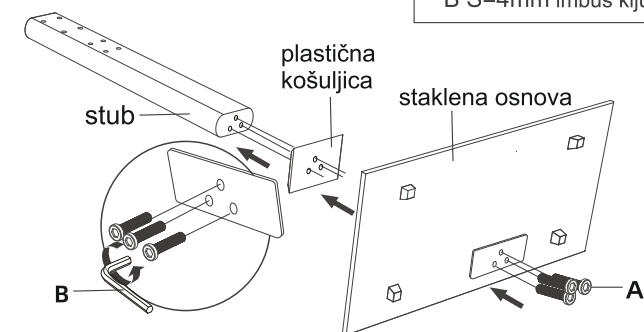

A M6x35mm*3
B S=4mm imbus ključ

Pre pritezanja zavrtnja nosećeg stuba, uverite se da ste ga postavili vertikalno a da je baza horizontalna.

3 Instalacija noseće ploče

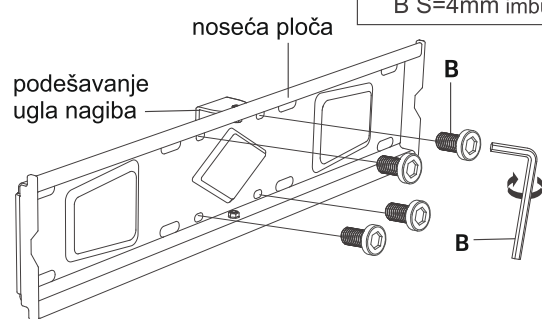

B M6x10mm*4
B S=4mm imbus ključ

Postavite mehanizam za nagib na noseću ploču i učvrstite ga sa M6x10mm zavrtnjima.

4 Install TV plate to the column

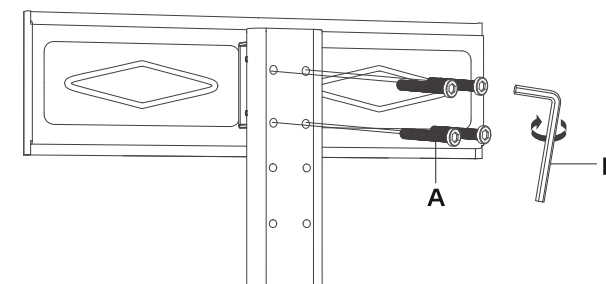

A M6x35mm*4
B S=4mm imbus ključ

Na noseću ploču postavite stub i fiksirajte ga sa zavrtnjima M6x50mm pošto izvršite nivelisanje

5 Postavljanje vertikalnih šina na TV

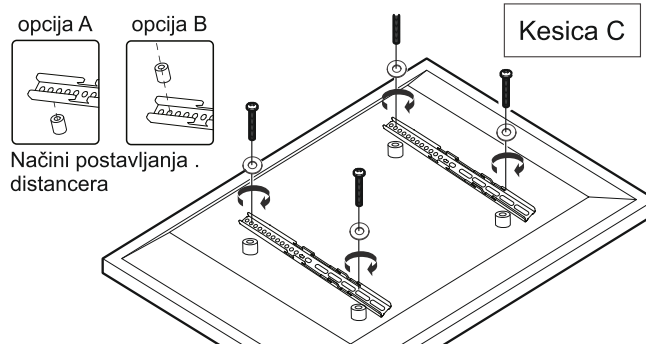

Načini postavljanja .
distančera

Izaberite iz kompleta adekvatne zavrtnje koji odgovaraju tipu Vašeg TV za fiksiranje vertikalnih nosača na pozadinu TV

6 Pritezanje sigurnosnih zavrtnjeva

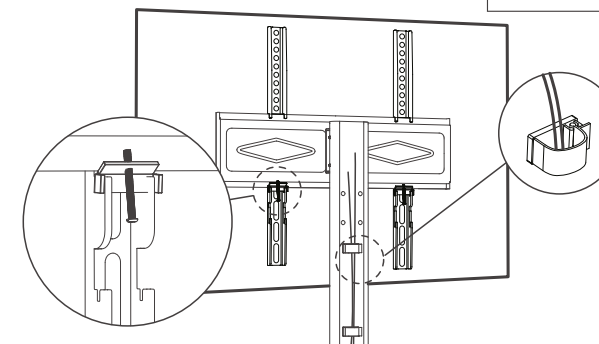

C M5x40mm*2

Okačite TV na noseću ploču pa potom pritegnite sigurnosne zavrtnje. Sa zadnje strane postavite kabl klipse i provucite kabl kroz njih.